

# INSTRUCTION MANUAL



**KEPCO** An ISO 9001 Company.

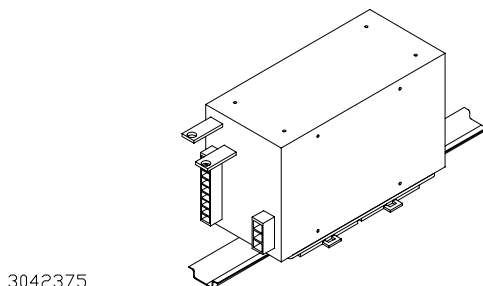
**KIT  
DIN RKW-600L**

## DIN-RAIL MOUNTING KIT FOR SERIES RKW 600W

**DESCRIPTION.** Kepco Kit, Model DIN RKW-600L contains a preassembled mounting plate and associated hardware used to install RKW 600 Watt Series power supplies on a DIN rail. The "L" suffix is for mounting perpendicular to the long dimension (length) as shown in Figure 1. Outline dimensions are shown in Figure 4.

### INSTALLATION.

**1. INSTALLING KIT.** Attach the preassembled mounting plate to the power supply using the hardware supplied (see Figure 3).



**FIGURE 1. L SUFFIX ORIENTATION**

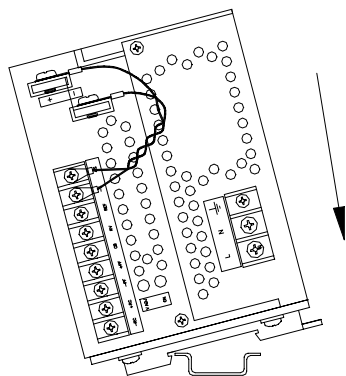
**2. INSTALLING POWER SUPPLY ON DIN RAIL.** To mount the power supply on the rail insert one end of both clips under one edge of the rail, then snap the other end of the clips into place (see Figure 2A).

**NOTE:** For applications where the installed power supply may be subject to unusual levels of shock or vibration, or where the power supply is oriented such that it may slide down the rail due to gravity, the use of two DIN rail end stops (Kepco P/N 108-0367) is recommended. After installing the power supply on the rail, the end stops are installed by clearing the DIN rail of other components and sliding the end stops over the rail. When the end stops are secure against the power supply, tighten the two integral screws of each end stop.

**3. WIRE POWER SUPPLY.** Refer to RKW 600W manual.

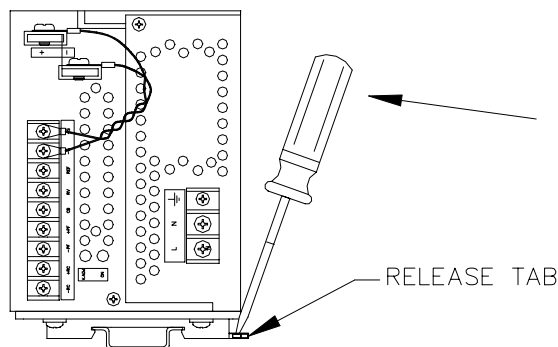
**REMOVING POWER SUPPLY FROM DIN RAIL.** While grasping the power supply with one hand, use a screwdriver to apply leverage towards the left as shown in Figure 2B to disengage both clips from the rail.

### A - INSTALLATION



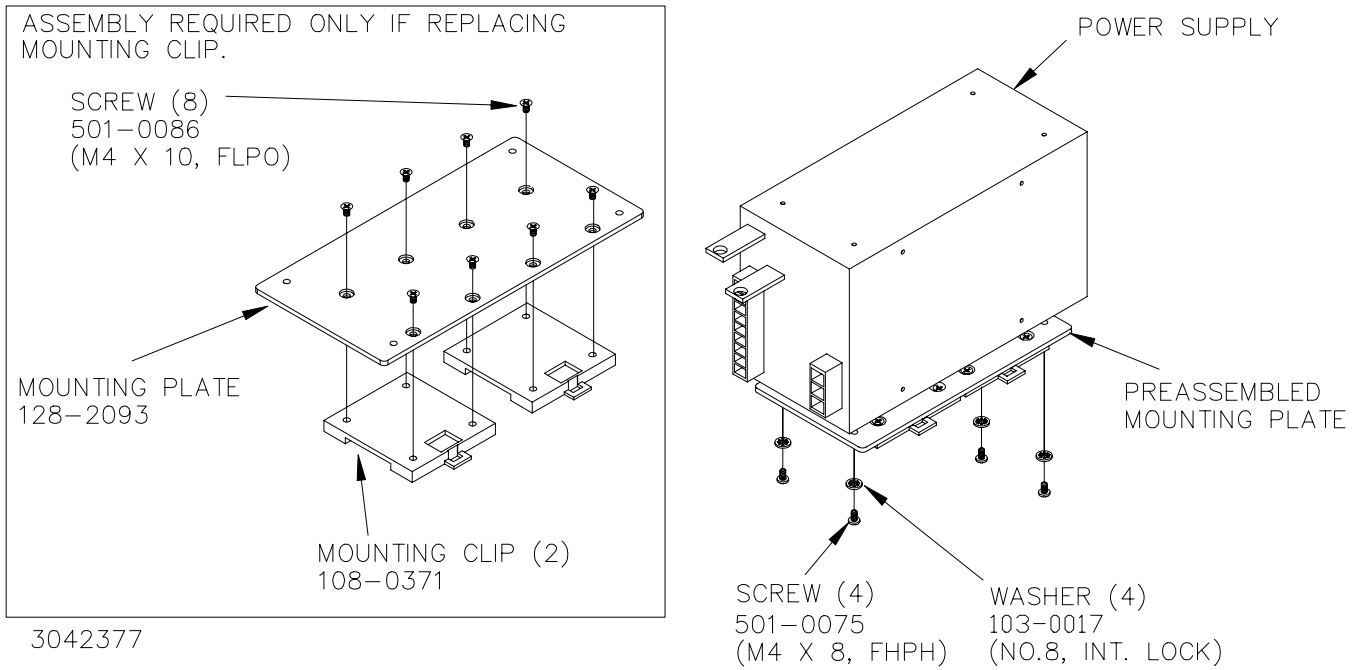
3042376

### B - REMOVAL

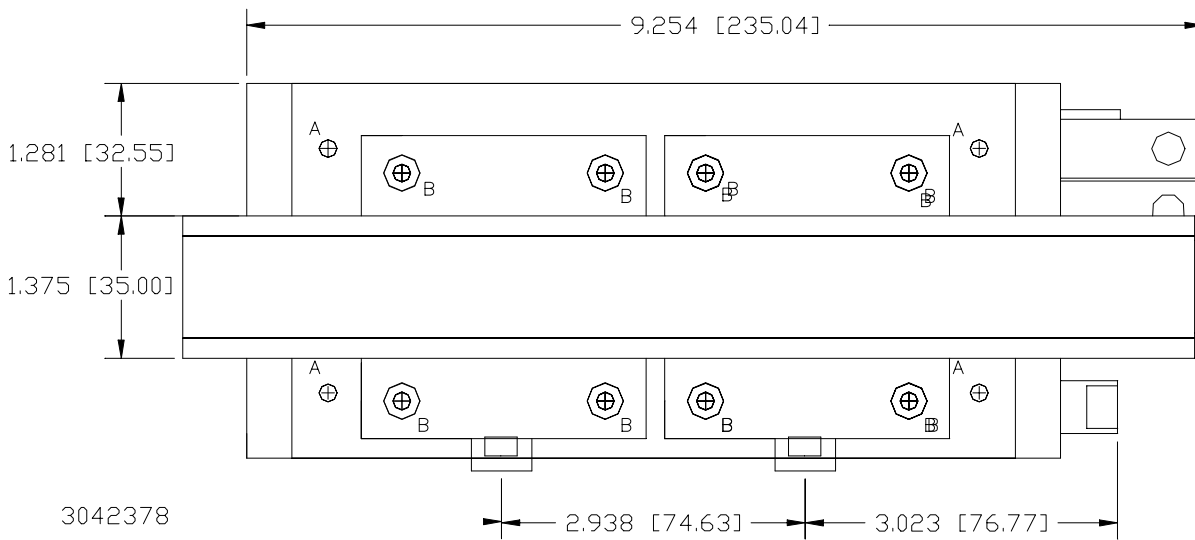


**FIGURE 2. INSTALLATION AND REMOVAL OF POWER SUPPLY FROM DIN RAIL**

KEPCO, INC. ● 131-38 SANFORD AVENUE ● FLUSHING, NY. 11352 U.S.A. ● TEL (718) 461-7000 ● FAX (718) 767-1102  
<http://www.kepcopower.com> ● email: [hq@kepcopower.com](mailto:hq@kepcopower.com)



**FIGURE 3. INSTALLATION OF KIT ON RKW 600W POWER SUPPLY**



**FIGURE 4. RKW 600W POWER SUPPLY WITH KIT INSTALLED, OUTLINE DIMENSIONS**